



# RES & UNV 30A Relay Kit

RES-RLYKIT

## INSTALLATION INSTRUCTIONS

### WARNING

BY INSTALLING OR USING THIS PRODUCT YOU AGREE TO OUR "END USER AGREEMENT". IT IS INCLUDED WITH THESE INSTRUCTIONS AND AVAILABLE ON-LINE AT <http://www.3built.com/documents.asp>

Use of this product could result in injuries to the rider due to the sudden loss of engine power. Motorcycles and ATV's may lose stability when engine power is disabled. Control of the vehicle will also be limited after engine is disabled. This product will not stop a vehicle. It will not apply the brakes or any other mechanism to reduce speed. It is designed to disable the engine by shutting off the ignition system. It functions similarly to the vehicle's stock (OEM) STOP/RUN switch. Use extreme caution as to when and where the vehicle is before disabling the engine. Proper judgment must be used when disabling engine power. Performance and range is not guaranteed. Radio frequency interference may be common in some areas. Use of motorcycles and ATV's is an inherently dangerous activity. Wear proper protective gear when operating the vehicle. If any doubt of potential injury, do not use. Once installed, to understand how this product functions, test the device by disabling the vehicle's engine, first at idle and then at low speed. This product's installation and use is at your own risk.

### INCLUDED PARTS

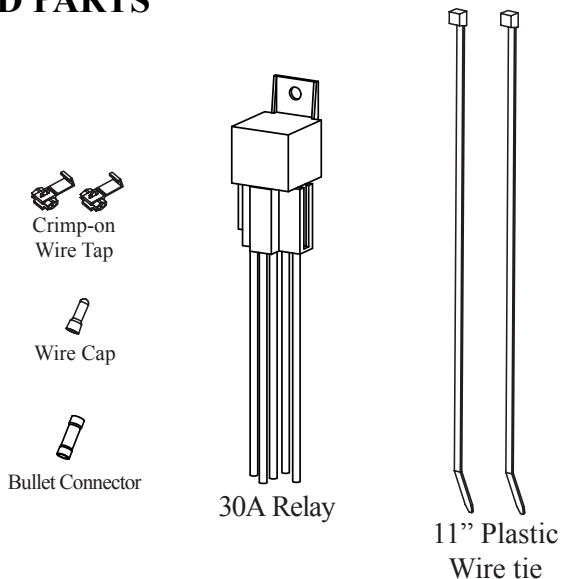

### GETTING STARTED

- 1) Installation of this device requires electrical and electronics knowledge.
- 2) You should have a wiring diagram for your vehicle before installation.
- 3) Do not connect any RES wire to the high voltage spark plug wire.
- 4) This device is a remotely activated relay. The relay can be connected as a normally-open or normally-closed relay while the vehicle is in the RUN mode.
- 5) It is important to determine your OEM (original equipment manufacturer) RUN/STOP switch type before installation. Improper installation of this unit can damage your vehicle's electrical system and CDI. If unsure, please consult a professional.
- 6) DEFINITIONS

**OEM** - Original Equipment Manufacturer. This is any component that the vehicle originally came equipped with from the factory.

**RES** - 3Built's Remote Engine Shut-off kit

**Normally-open** - means that the relay is open (no connection) when the RES is in the unlocked mode. This connection type is typically used for ground type OEM RUN/STOP switches.

**Normally-closed** - means that the relay is closed (connected) when the RES is in the unlocked mode. This connection type is typically used on positive voltage type OEM Run/Stop switches.

## INSTALLATION

- 1) Connect the Blue wire from the RES Receiver to the Red wire from the RES Receiver with Crimp-on Wire Tap.
- 2) Connect the Blue wire from the Relay to the Green wire from the RES receiver with the Bullet Connector.
- 3) Connect the Yellow wire from the Relay to the Black wire from the RES receiver with Crimp-on Wire Tap.
- 4) Cut and attach the Wire Cap to the Yellow wire from the RES receiver.
- 5) Connect the Red & Black wire from the RES receiver per the RES Installation Instructions.
- 6) Connect the Black, Red & White wire from the Relay per the normally open or normally closed instructions on the RES Installation Instructions. Note the wire color difference below.
  - 6a) For **Normally Open Connection**: Use the **Black and White wire pair**. Cap Red wire.
  - 6b) For **Normally Closed Connection**: Use the **Black and Red wire pair**. Cap Black wire.
  - 6c) **Relay switching current limited to 30 amperes.**

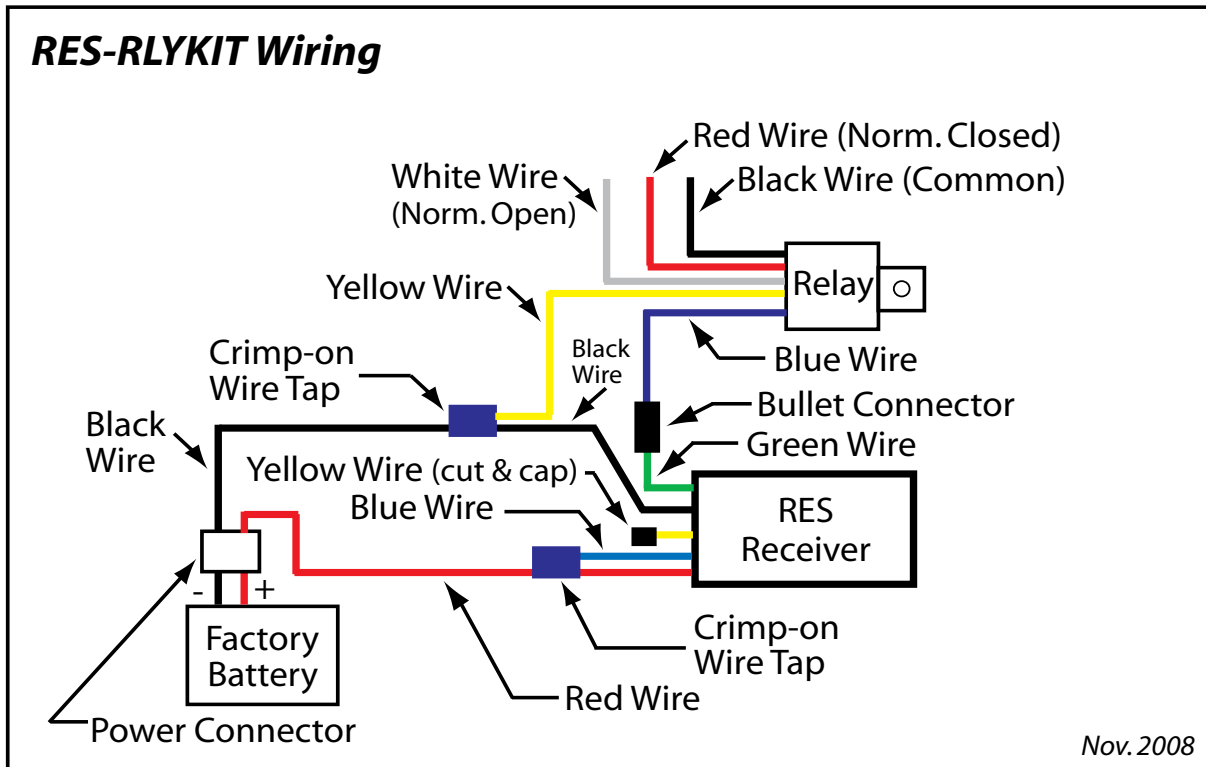

**3Built llc**  
www.3built.com

Technical Support: techsupport@3built.com  
Sales: sales@3built.com  
818-574-5334